

BANZAI

**1/10 SCALE 4WD READY-TO-RUN
BRUSHED ELECTRIC MOTOR
POWERED DRIFT STREET CAR**

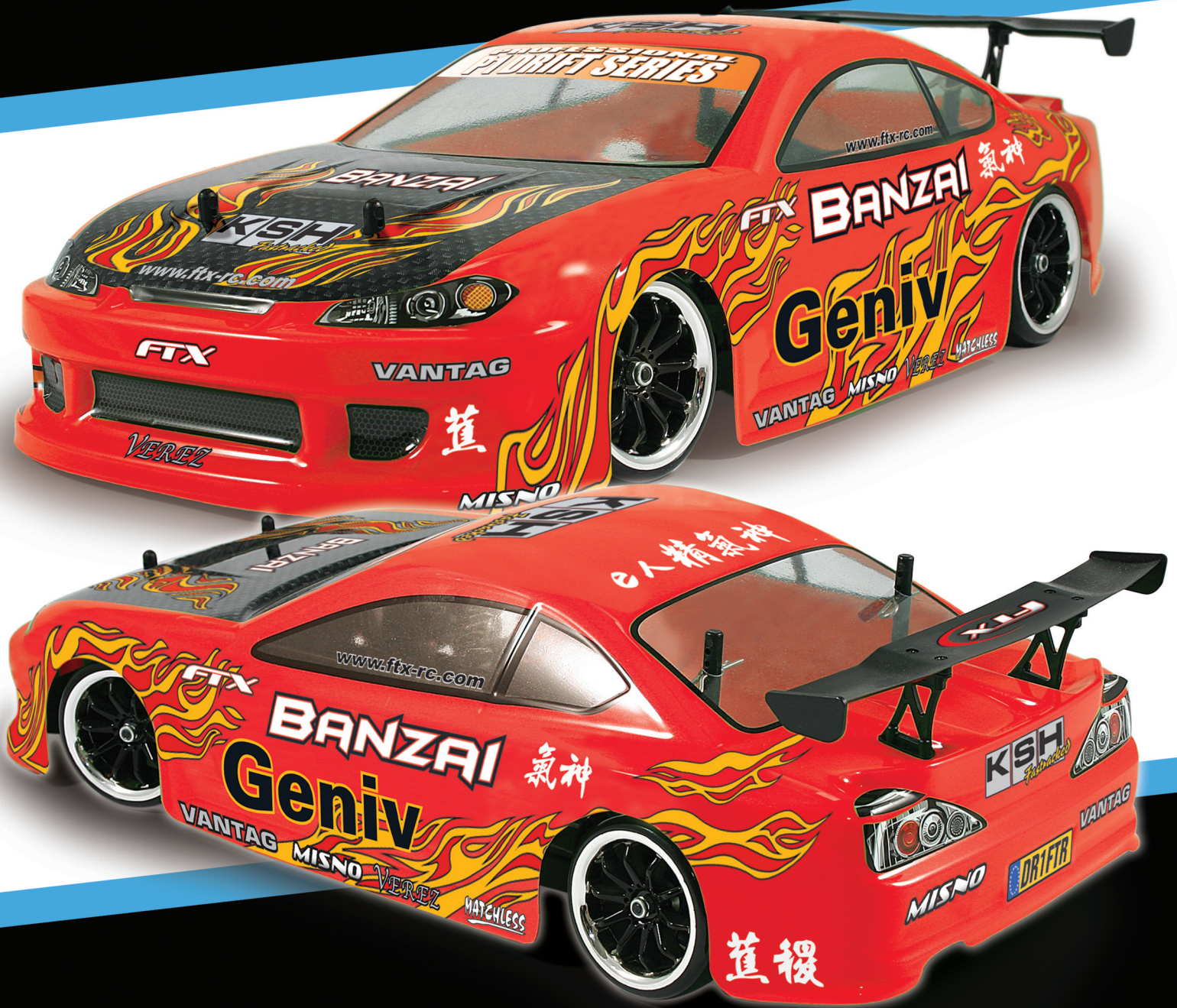

SET-UP INSTRUCTIONS AND PARTS LISTING



FTX Banzai RTR Brushed 2.4GHz 4WD Drift Car

Congratulations on your purchase of the FTX 'Banzai' electric Drift car.

This 1/10th scale model has been factory assembled and all electrics installed and set up to make it the easiest possible introduction to the sport of driving RC cars.



WARNING: Read the ENTIRE instruction manual to become familiar with the features of the product before operating. Failure to operate the product correctly can result in damage to the product, personal property and cause serious injury. This is NOT a toy and must be operated with caution and common sense. Failure to operate this product in a safe and responsible manner could result in damage, injury or damage to other property. This product is not intended for use by children without direct adult supervision.

It is essential to read and follow all the instructions and warnings in the manual, prior to assembly, set-up or use, in order to operate correctly and avoid damage or serious injury.

Safety Precautions and Warnings

- You are responsible for operating this model such that it does not endanger yourself and others, or result in damage to the product or the property of others.
- This model is controlled by a radio which is possibly subject to interference which can cause momentary loss of control so it is advisable to always keep a safe distance to avoid collisions or injury.
- Age Recommendation: 14 years or over. This is not a toy. This product is not intended for use by children without direct adult supervision.

Carefully follow these directions and warnings, plus those of any additional equipment associated with the use of this model, chargers, ESC and motors, radio etc.

- Never operate your model with low transmitter batteries.
- Always operate your model in an open area away from cars, traffic or people.
- Never operate the model in the street or in populated areas.
- Always keep the vehicle in direct line of sight, you cannot control what you cannot see!
- Keep all chemicals, small parts and anything electrical out of the reach of children.
- Avoid water exposure, moisture causes damage to electronics and may result in the loss of control or permanent damage.
- Avoid injury from high speed rotating parts, gears and axles etc.
- Novices should seek advice from more experienced people to operate the model correctly and meet its performance potential.
- Exercise caution when using tools and sharp instruments.
- Do not put fingers or any objects inside rotating and moving parts.
- Take care when carrying out repairs or maintenance as some parts may be sharp.
- Do NOT touch equipment such as the motor, electronic speed control and battery, immediately after using your model because they can generate high temperatures.
- Always turn on your transmitter before you turn on the receiver in the car. Always turn off the receiver before turning your transmitter off.
- Keep the wheels of the model off the ground, and keep your hands away from the wheels when checking the operation of the radio equipment.
- Prolong motor life by preventing overheat conditions. Undue motor wear can result from frequent turns, rapid change of direction forwards/backwards, continuous stop/starts, pushing/pulling objects, driving in deep sand and tall grass, or driving continuously up hill.

Contents:

Banzai 1/10th RTR Electric Drift car.
Transmitter: 2.4GHz Steerwheel.
Charger: Input Mains 240V AC. Output 300mA DC
Battery: 7.2V 1800mAh NiMH
Aerial Tube



Required equipment for operation

1. Tools required for building and maintenance:

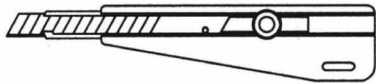

● Hobby knife

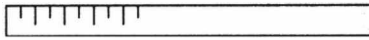

● Precision ruler

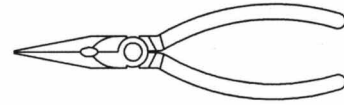

● Needle nose pliers

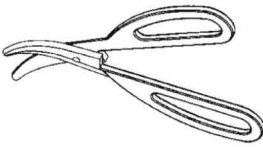

● Lexan scissors

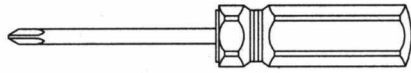

● Flat and Philips screwdriver

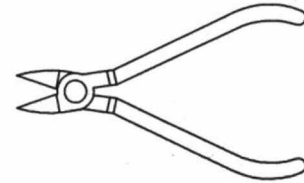
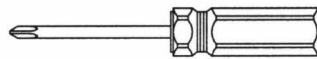

● Wire cutters

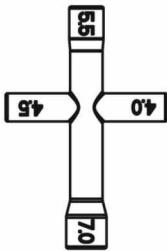

● Cross wrench

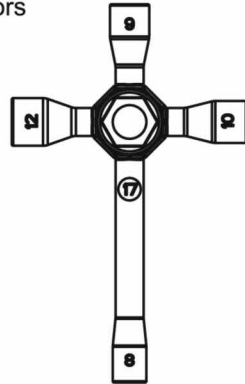

● Cross wrench



● CA glue&rubber cement



● Thread locking compound



1.5mm



2.0mm



2.5mm

● Hex wrench

WARNING!

Do not use a power screw driver to install screws into nylon or plastic materials. The fast locking may heat up the screws being installed that may break the molded parts or strip the threads during installation.

2. Additional items needed for operation:

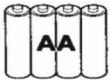

4pcs AA alkaline batteries for transmitter

IMPORTANT!

Check that all screws and nuts are tight before each use.



Aerial Assembly.

Uncoil the aerial wire carefully so as not to kink or knot it in anyway, and first be sure to insert the wire up through the top chassis aerial mount hole from below. Pull the rubber tube cap off the aerial tube and push the wire all the way through the aerial tube until the first 5mm of wire shows out of the other end. Fold the wire down over the end of the tube and be sure to insert the rubber tube cap so that it traps the protruding wire to hold it firmly in the tube. Push Aerial tube into mounting hole in upper chassis until firmly seated. Bundle any excess aerial wire neatly away from rotating components on the chassis.

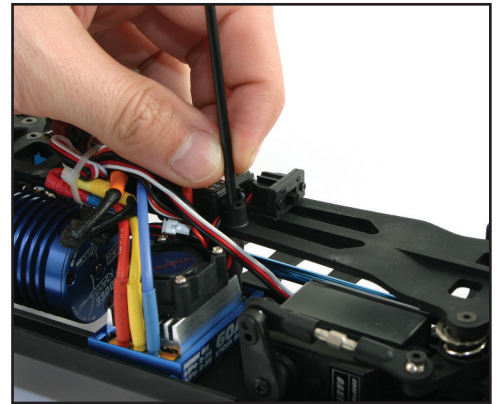
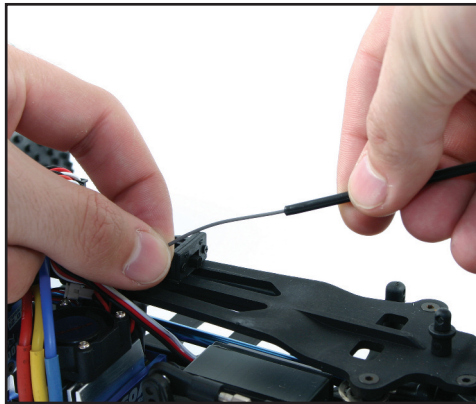
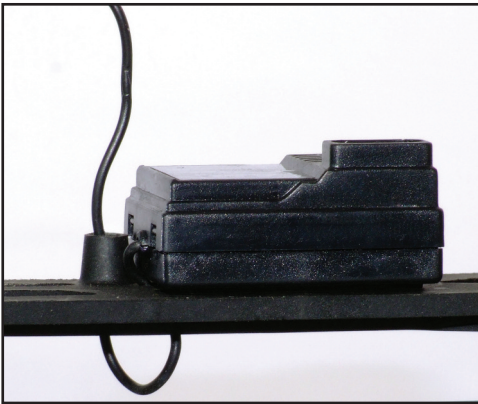

Charging/Installing the Battery.

Always store your model with the battery pack unplugged and removed. Always charge your battery away from the vehicle. The included 300mAh mains charger will take approx 6 hours to charge a fully discharged battery, but always remove it from the charger if it becomes warm to the touch. Always disconnect the charger from the mains supply and the battery pack when not in use. Keep children away from charger and battery during the charging process.

To install a charged battery, remove the body clips and remove the bodyshell. Remove the battery retainer clips, insert battery and reinstall retainer with the flat side facing the battery and re-insert clips. When connecting battery and turning car on, ensure it is off the ground, with wheels away from objects.

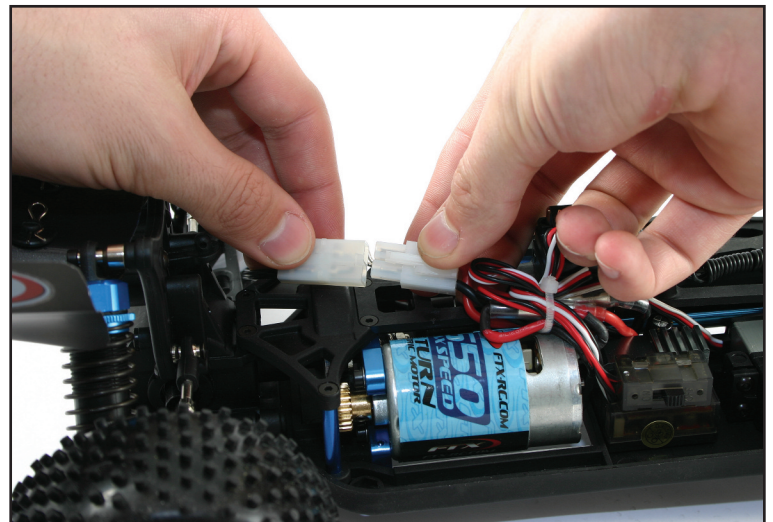

Notes on Battery use:

Always allow the battery cool after use, before recharging.

Always inspect the battery before charging.

Any bare wires, split heat shrink or leakage is a sure sign of abuse.

Never attempt to charge dead or damaged batteries.

Do not disassemble the battery or cut the connector wires.

If the battery connector gets hot enough to melt there is most likely a serious problem with your model, driveline, battery wires or speed controller. Find and correct the problem before installing another charged battery pack.

NEVER charge the battery unattended incase of overcharging, you need to be able to monitor the battery during charging

Charge away from flammable objects and on a non-flammable surface incase the battery becomes too hot.



Speed Control Set Up

FEATURES:

This ESC is set up in a simple way for easy operation. When switched on, it automatically searches the neutral point. When the automatic setup is finished, the motor sends out "DO" "RE" "MI" music indicating it snatches the neutral point. It's easy to operate.

SPECIFICATIONS:

- ▲ INPUT: 7.2v 6-cell NiMH DC (not LiPO compatible)
- ▲ BEC:5V 1A
- ▲ Current Drain: 20A, Max Forward 300A (instantaneous), Max Reverse 150A (instantaneous)
- ▲ Size: 35mm(L) X 33mm(W) X 30mm(H) Weight: 48.2g
- ▲ Applicable: 540/15T motor and above.

Wire diagram:

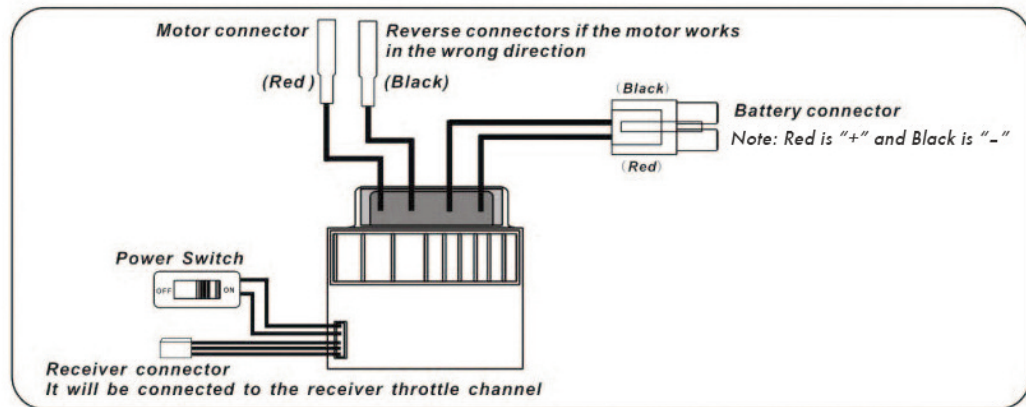

SETUP:

Connect all wires according to the diagram, then switch on the radio. (Put to default setting for Programmable Radio). Switch on the power of the ESC, and you'll hear "DO, RE, MI" music. The music indicates that the transmission is on, and the neutral point is set up. If the motor does not stop running a short while after the neutral point is set, please switch off the ESC and then switch it on again to get the neutral point.

FUNCTIONS:

- ▲ Forward: Press the trigger and the car will move forward. If the car is moving a little then adjust the trim (No.8 on Transmitter picture).
- ▲ Brake: To brake allow the trigger to return to neutral point
- ▲ Reverse: Push the trigger forward and the car will go into reverse. The car must be stationary before reverse engages. This protects the esc from excessive forward/backwards action.
- ▲ LED indicator is always on during forward, reverse and brake mode. When the ESC is not working and the car stops, LED indicator is off. When the radio is switched off, LED indicator on the ESC flashes.

Warning:

- ▲ Although this esc is waterproof the rest of the vehicle is not. Do not run the model in excessively wet conditions or submerge as long term damage and wear can occur.
- ▲ It is dangerous to touch the motor after running as it emits heat during running and the cooling plate remains hot after running.
- ▲ This ESC is not LiPO battery compatible. Use with Lipo will damage the ESC permanently



2.4GHz Transmitter Set-Up

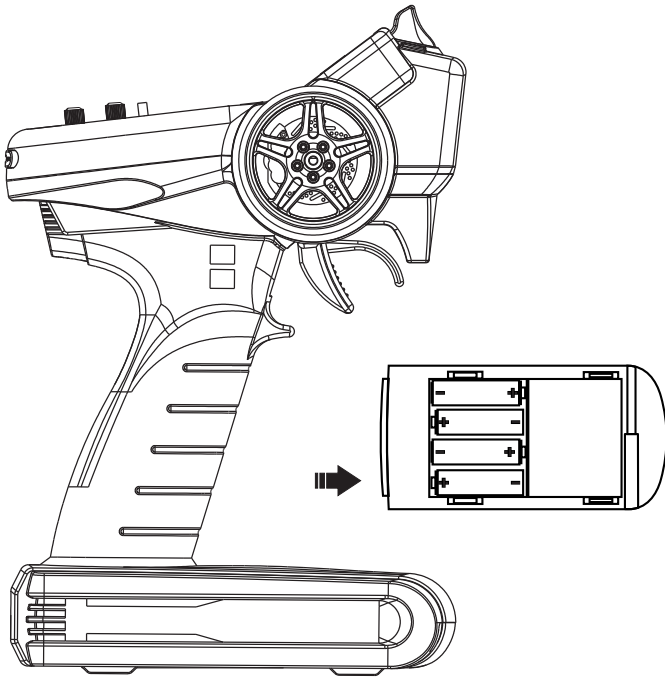

Install the batteries

- (1) Remove the battery compartment cover.
- (2) Replace the used batteries with new AA size batteries.

Please replace batteries when the power indicator blinks or the buzzer beeps.

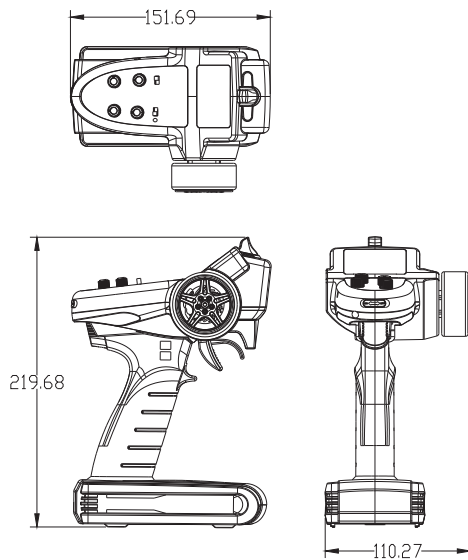

Function

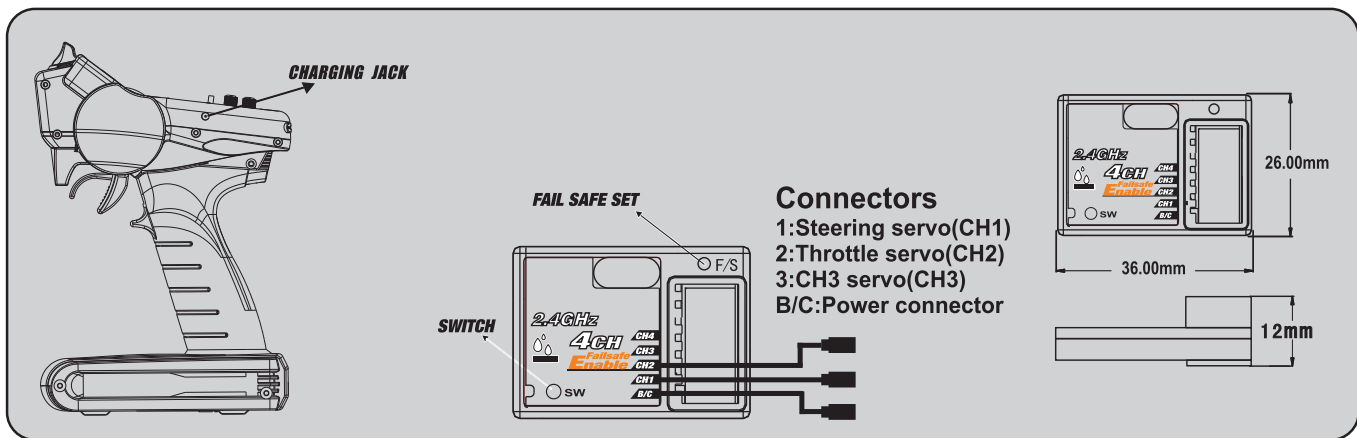
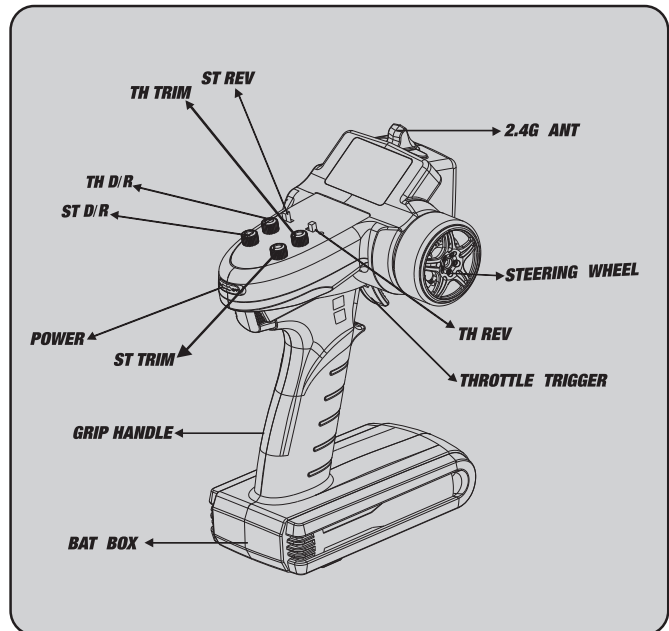



2.4GHz Transmitter Adjustment

A. Throttle Trigger

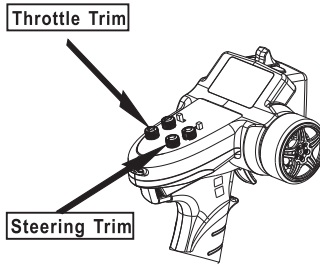
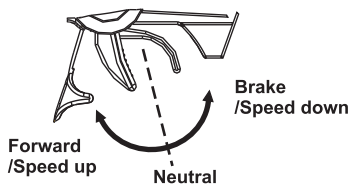

⚠ Keep the transmitter and receiver 40cm apart when operating.

Use the REV switches to reverse the steering or throttle operating direction.

1. Push the trigger forward to slow down or brake.
2. Pull the trigger backward to accelerate.

B. Steering Wheel

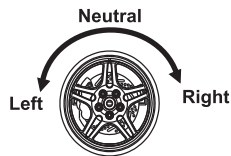

Throttle Trim: Trim the throttle servo slightly when the trigger is at the neutral position.

Steering Trim: If the front wheels do not align straight, use the steering trim to adjust.

Low battery alarm

Do not operate the radio system when the battery power is low. The battery power is low.

Fail Safe Function Setting

1. Set the TH, ST switches to the normal position.
2. Turn on the transmitter and receiver.
3. Press the F/S SET button, the LED on the receiver should start flashing rapidly.
4. Put the throttle trigger at the brake position, press the F/S SET button, the LED should become solid.
5. For electric model, put the throttle trigger at the stop position when you are making the setting.

Electrical powered model

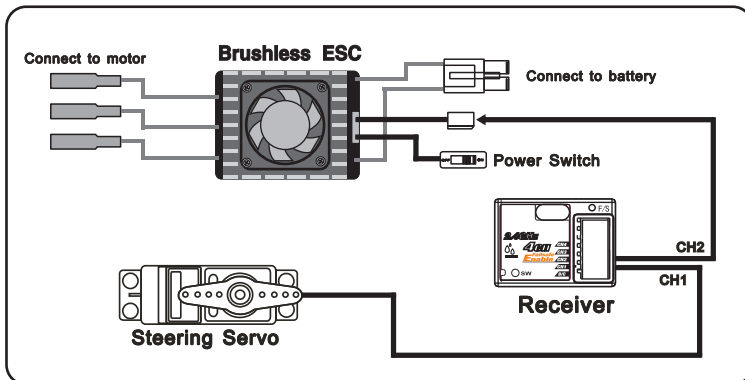
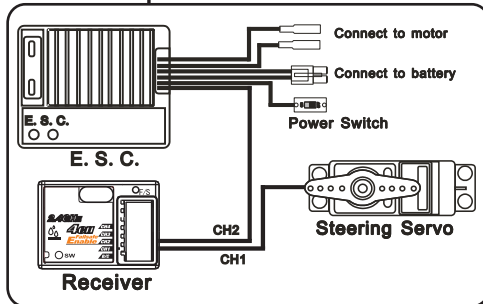

Binding the transmitter and receiver

1



1. Turn on the receiver power. Press the SW switch. The receiver's LED should start flashing.

2

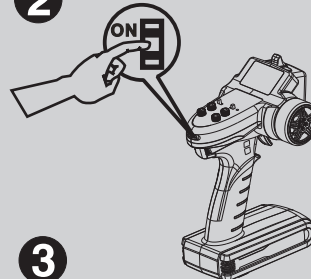

2. Turn on the transmitter.

3

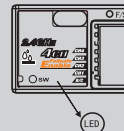

3. When the LED on the receiver becomes solid, the binding process is completed.



Getting Started

Switch on transmitter.

Hold vehicle clear of the ground, connect battery pack and switch on receiver.

Bind the Transmitter and receiver if required.

Test the transmitter to check control of the vehicle with wheels off the ground.

Start driving slowly and if the vehicle does not go straight, adjust steering trim dial on Transmitter.

For the very first run use the throttle gently, to gradually bed in the motor brushes and help the driver become accustomed to the vehicles behaviour and controls.

PLEASE NOTE:

Although the electronics are waterproof the rest of car can be subjected to damage if running in excessively wet or submerged conditions.

After Run.

Switch off the receiver power, switch off the transmitter and lower the aerial. Disconnect the battery and remove it from the vehicle, allow it to cool before recharging. If you have a second charged battery all ready to use, still allow the vehicle to cool slightly before continuing.

Regular maintenance.

Frequently check the whole vehicle for loose or missing fixings. Use thread lock on any replacement screws into metal threads.

Frequently check rotating parts are free from grass, string etc. that might bind their motion and over stress the motor or speed controller. Remove the wheels occasionally and check behind the mounting hex for obstructions or anything that might have been wrapped around the axle and caused extra drag.

Check the gear mesh frequently and remove any stones or grit from gear teeth to prevent premature wear and damage.

If the motor moves, or is removed for maintenance/exchange, the gear mesh will need to be set. Simply slacken the motor retaining screws and adjust the motor until there is just discernable backlash between pinion and spur teeth. If the gear is too tight or too loose the gears will be noisy and could be damaged.

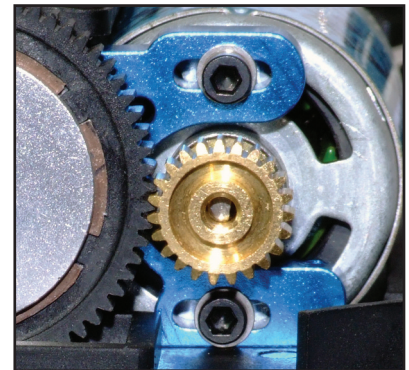

Shock absorbers will wear prematurely if used in dirty dusty conditions. Replace oil and seals as required to keep a smooth dampening action.

Trouble shooting guide.

<p>Short Runtime: Battery damaged/not charged Motor dirty or brushes worn Drivetrain binding</p>	<p>Sluggish Action: Motor dirty or brushes worn Bind in drive train Battery running low on power</p>	<p>Motor/ESC overheat: Over-gearred Binding transmission. Seized axle bearing. Motor binding</p>	<p>Motor spins but vehicle refuses to move: Gears damaged. Gears loose on shaft. Slipper clutch too loose. Drive shaft broken or missing.</p>	<p>Poor Range or fails to operate: Transmitter batteries low Vehicle Battery Low. Transmitter switched off Transmitter/receiver aerial not extended. ESC switched off or battery not connected. Loose connectors/wires. Water damage. Model electronics are not waterproof.</p>
---	---	---	--	--

Warranty

Due to the nature of this product and potential use FTX warrants it to be free of material and workmanship defects when new. FTX will at its sole discretion repair or replace defective components free of charge within 30 days from date of purchase. This warranty does not cover wear and tear, crash or impact damage, modifications, component water damage failure to perform maintenance or damage from improper use. Proof of purchase date will be required to action any warranty claims.

Instructions for disposal.

This product must not be disposed of with other waste. Instead, it is the user's responsibility to dispose of their waste equipment by handing it over to a designated collections point for the recycling of waste electrical and electronic equipment.

For more information about where you can drop off your waste equipment for recycling, please contact your local council, your household waste disposal service or where you purchased the product.



FRONT & REAR SHOCK ASSEMBLY

Front Shocks

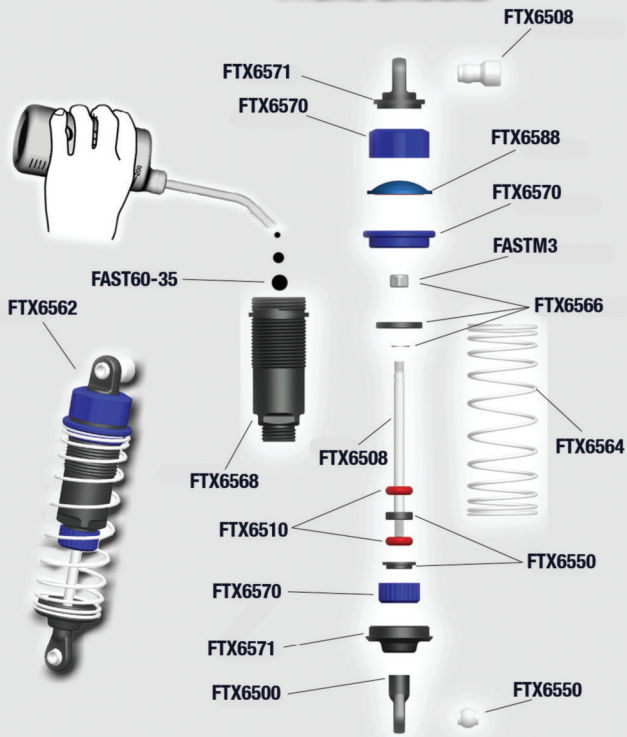

(Dia.3-1)

Rear Shocks

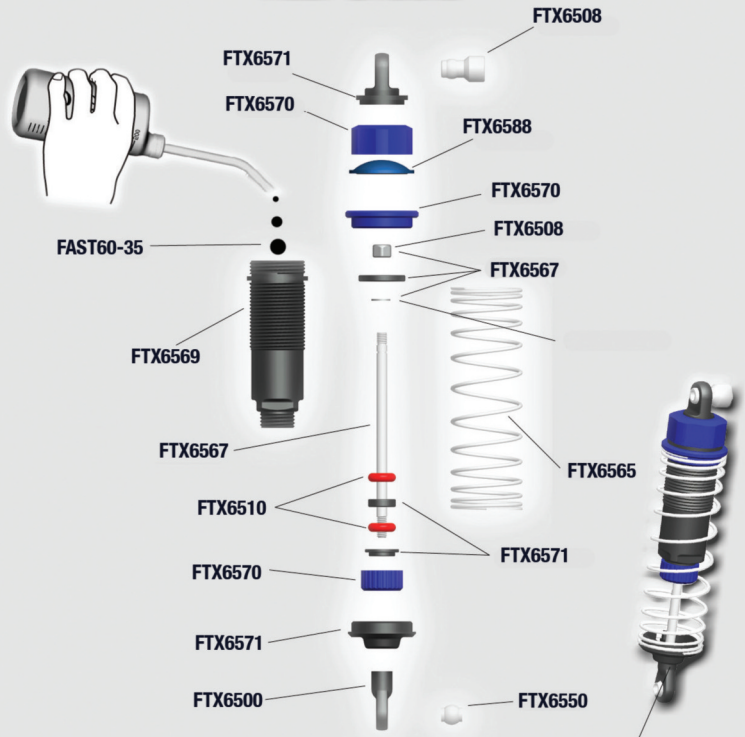

(Dia. 3-2)

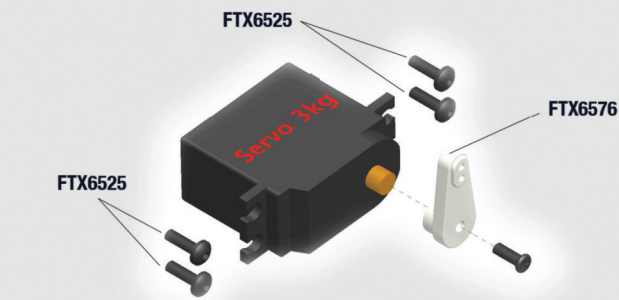

Steering Servo



(Dia.3-3)

Tyres



(Dia. 3-4)



Below you will see fitting instructions for the **OPTIONAL** front and rear anti-roll bars that are available for your drift or touring car.
Part number: FTX6487

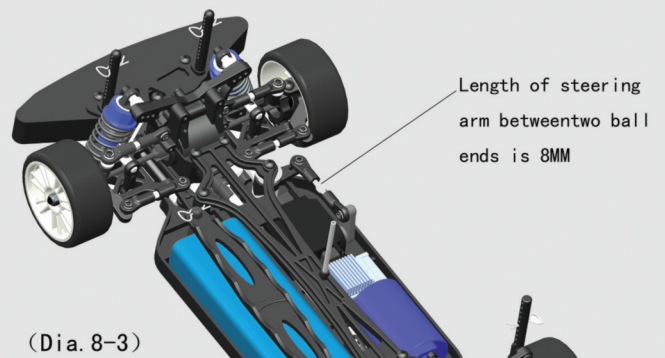
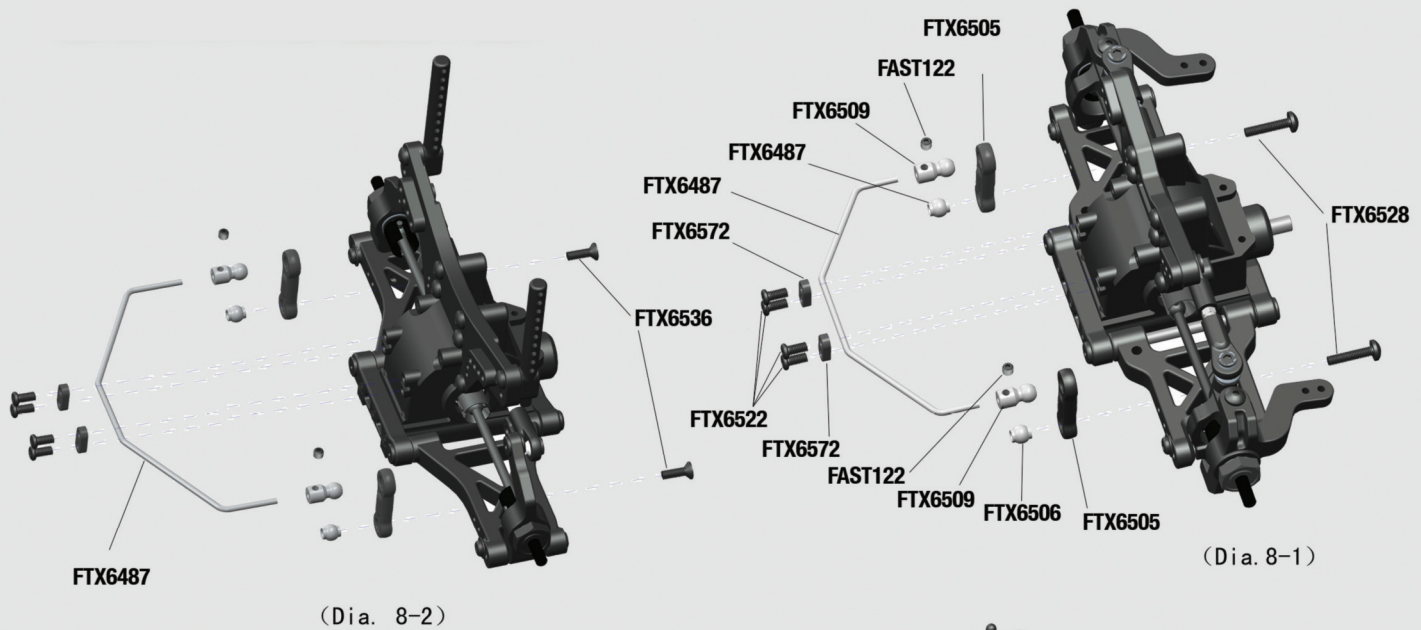

Front Bumper Assemblies.

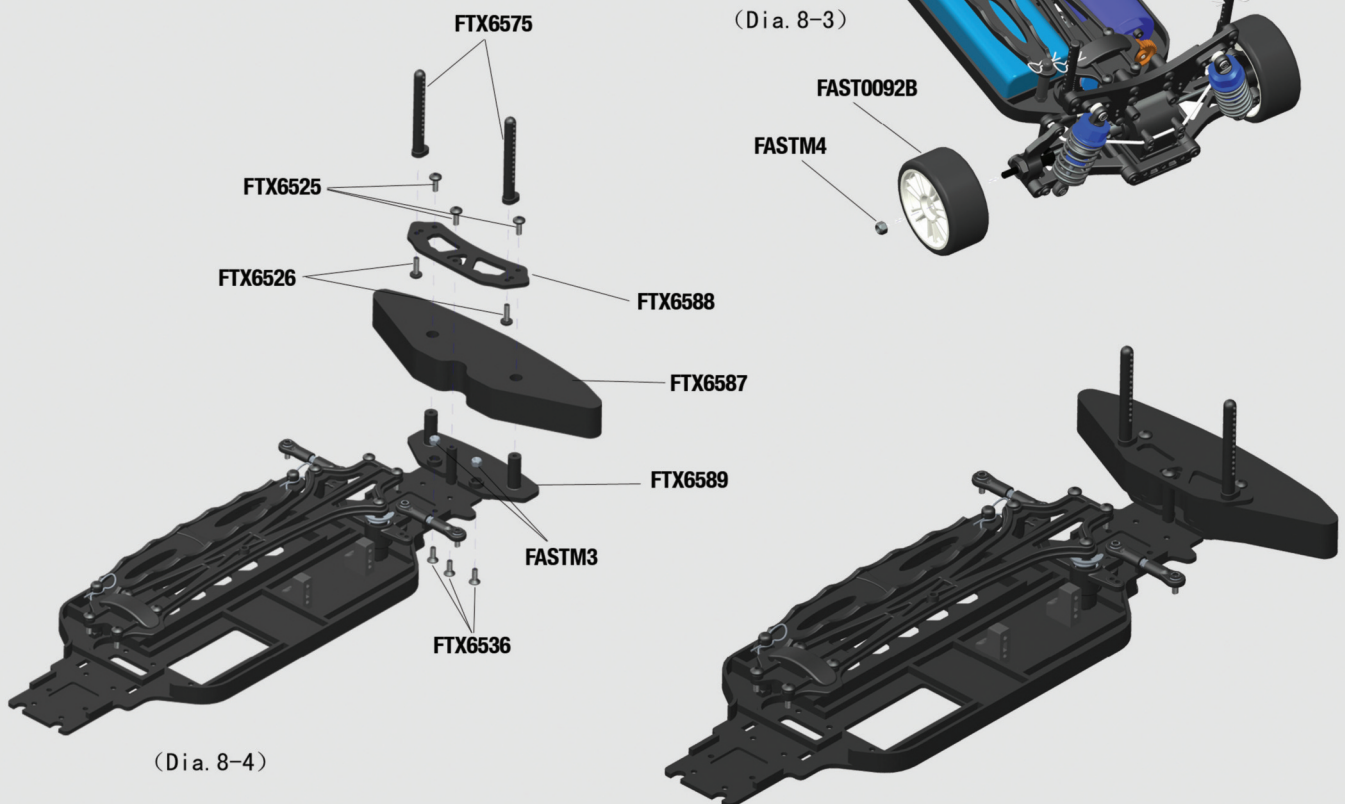

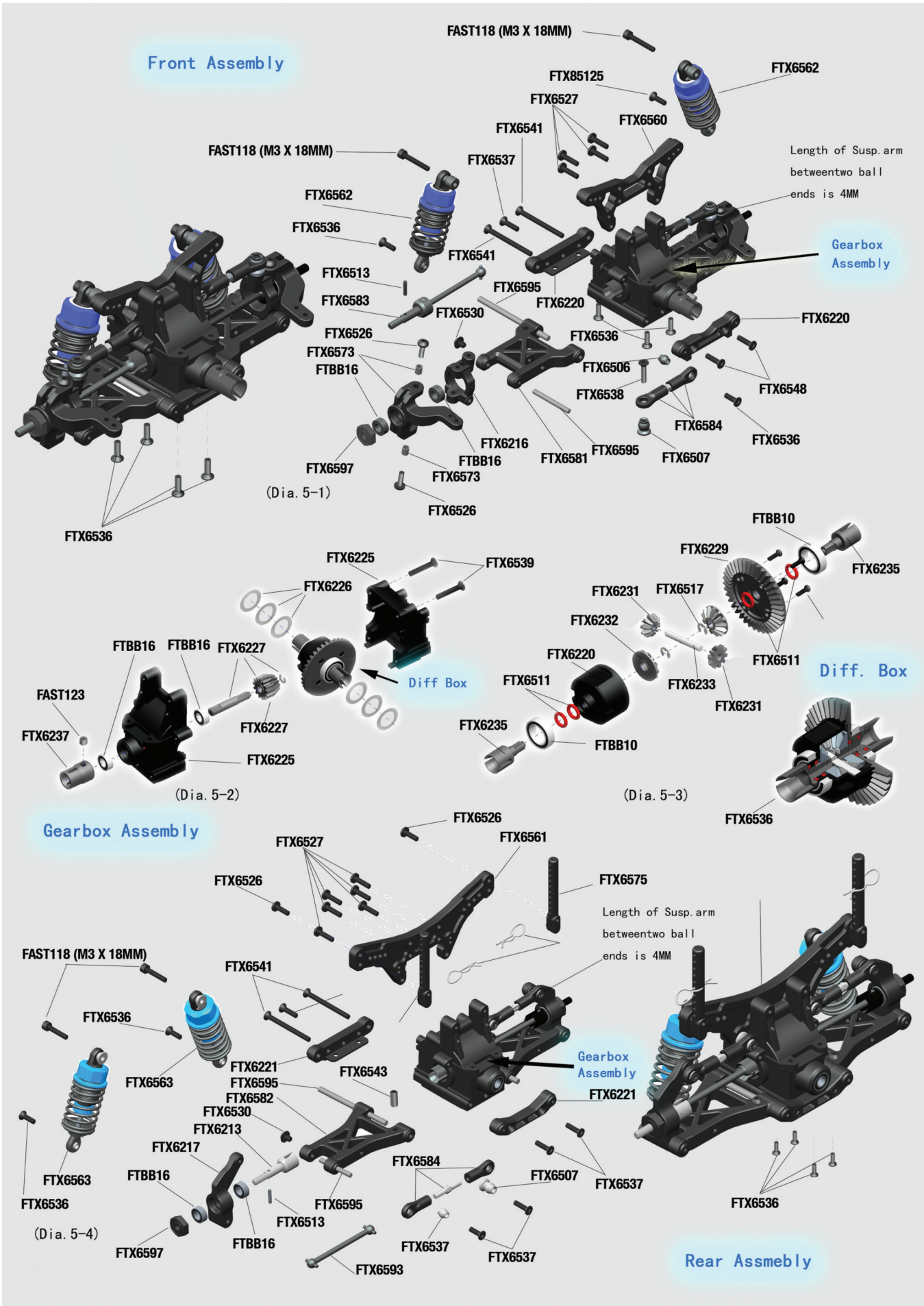



Central Assembly

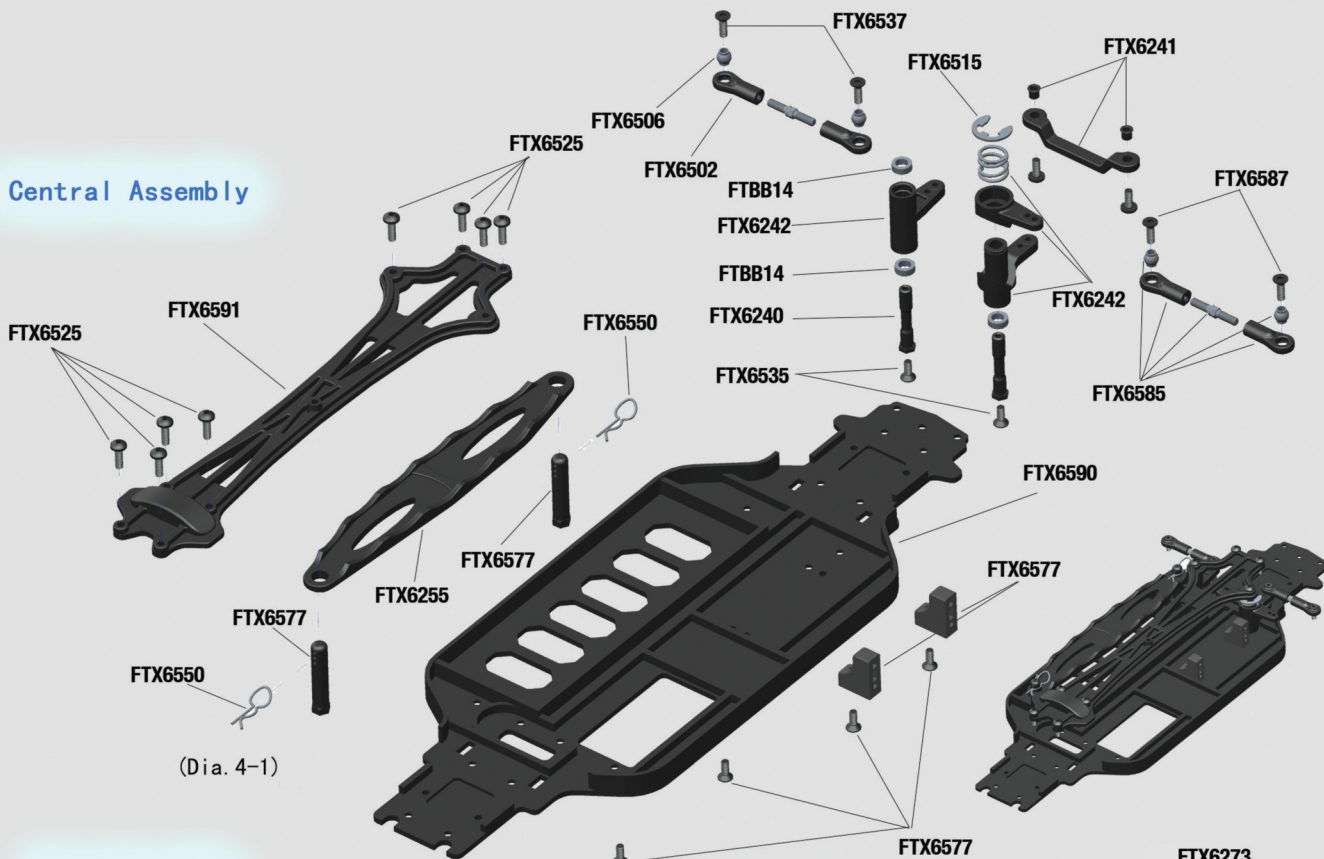

Rear Assembly

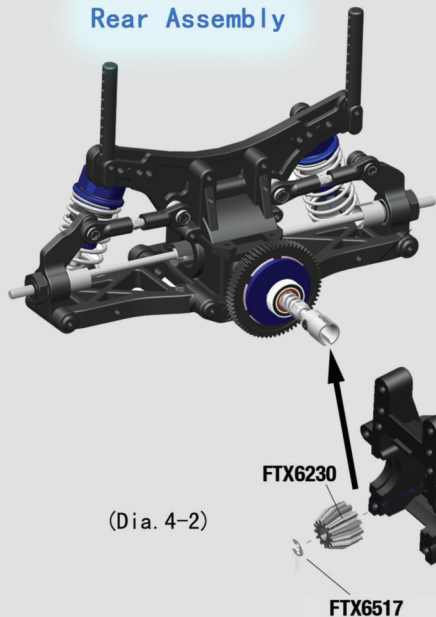

Motor Assembly

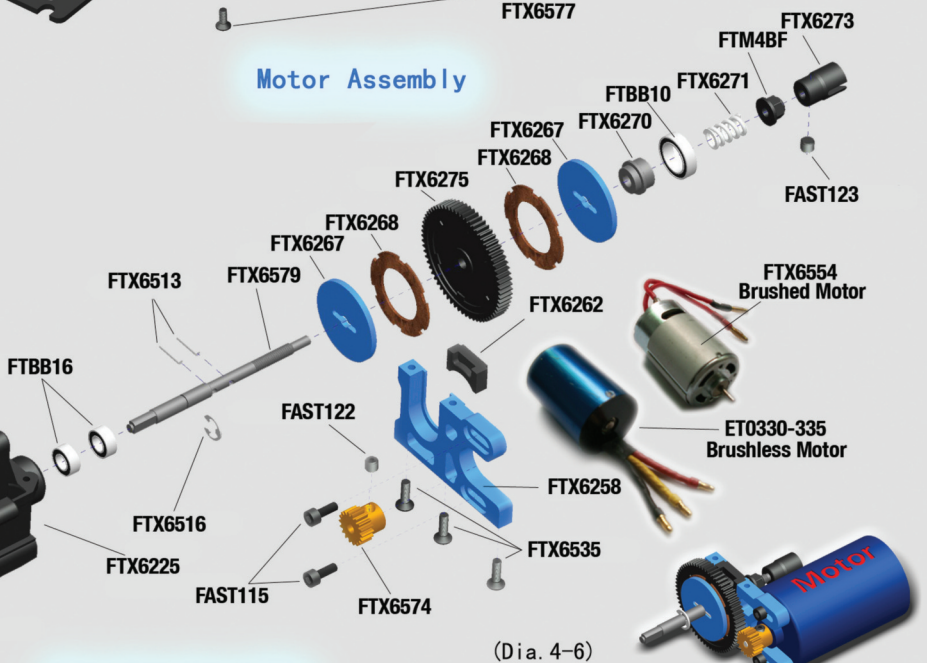

ESC



Steering Assembly

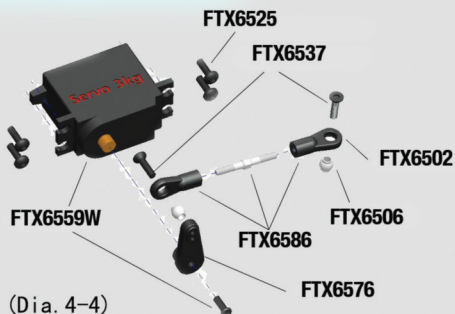













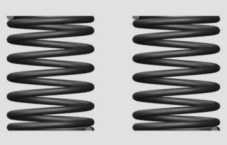
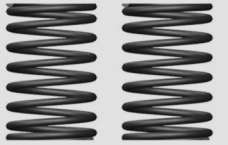



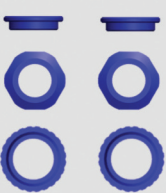
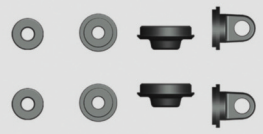

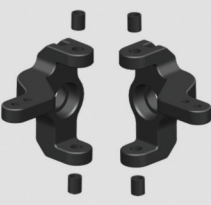
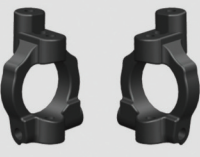
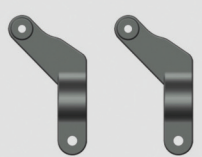
Receiver



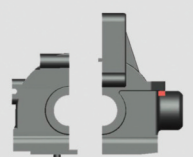

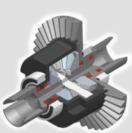









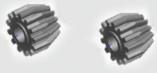
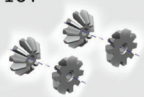
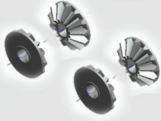



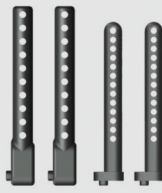
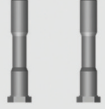



Common Part List

<p>FTX6560- Front Shock Tower 1pc</p> 	<p>FTX6561-Rear Shock Tower 1pc</p> 	<p>FTX6562-Front Shocks 2pc</p> 	<p>FTX6563- Rear Shock Tower 2pc</p> 
<p>FTX6564-Front Shock Spring 2pc</p> 	<p>FTX6565-Rear Shock Spring 2pc</p> 	<p>FTX6566-Front Shock Shaft & Piston Set 2sets</p> 	<p>FTX6597-Rear Shock Shaft & Piston Set 2sets</p> 
<p>FTX6568-Front Shock Body 2pc</p> 	<p>FTX6569-Rear Shock body 2pc</p> 	<p>FTX6570 -Shock Cap&Adjust Ring 2sets</p> 	<p>FTX6571-Shock Lower holder 2sets</p> 
<p>FTX6572-Sway Bar Fix Plate 6pcs</p> 	<p>FTX6573-Steering Knuckle Arm 1set</p> 	<p>FTX6216 -Uprights 2pc</p> 	<p>FTX6217-Rear Hub Carrier 2pc</p> 
<p>FTX6213-Rear Drive Shaft 2pc</p> 	<p>FTX6220-Front Susp. Holders 2pc</p> 	<p>FTX6221-Rear Susp. Holders 2pc</p> 	<p>FTX6225-Gearbox Housing Set 2pcs</p> 
<p>FTX6226-Diff 16T Gear Washer 6pcs</p> 	<p>FTX6227 -Diff. Drive Gear w/pin 2sets</p> 	<p>FTX6236-Diff Gearbox Set 1set</p> 	<p>FTX6228-Diff Case 2pcs</p> 





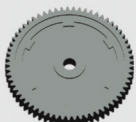

















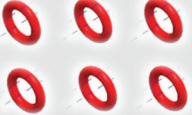
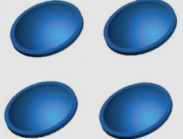

Part List

<p>FTX6230-Diff Drive Gear 2pcs</p> <p>13T</p> 	<p>FTX6235-Diff Bevel Gear S. 4pcs</p> <p>10T</p> 	<p>FTX6232 -Diff Bevel Gear B. 4pcs</p> <p>13T</p> 	<p>FTX6233-Diff pin 2pcs</p> 
<p>FTX6574-Pinion Gear 30T 1pcs</p> 	<p>FTX6235 -Diff Drive Cup 4pcs</p> 	<p>FTX6237 -Center Coupler 3pcs</p> 	<p>FTX6575 -Body Post 1set</p> 
<p>FTX6240-Servo Saver Post 2pcs</p> 	<p>FTX6241-Steering Ackerman 1set</p> 	<p>FTX6597-Wheel Hub 4pcs</p> 	<p>FTX6242 -Servo Saver 1set</p> 
<p>FTBB14 Bearing 8x5x2.5mm 6pcs</p> 	<p>FTX6576 -Servo Horn 1pc</p> 	<p>FTX6255 -Battery Cover 1pc</p> 	<p>FTX6577 -Battery and servo Post 1set</p> 
<p>FTX6505 -Sway Bar Holders 6pcs</p> 	<p>FTX6258 -Motor Mount 1pc</p> 	<p>FTX6578 -Slipper Complete 1set</p> 	<p>FTX6267 -Slipper Pad 2pcs</p> 
<p>FTX6268 -Slipper Gasket 2pcs</p> 	<p>FTX6275 -65T Spur Gear 1pc</p> 	<p>FTX6579 -Slipper Shaft 1pc</p> 	<p>FTX6270 -Slipper Spring Bracket 1pc</p> 

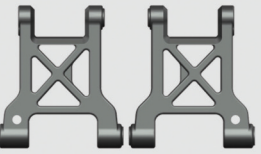
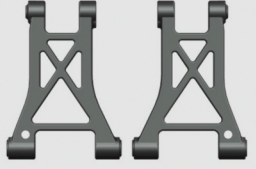

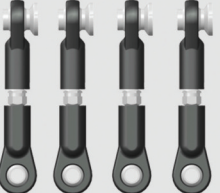





















Part List

<p>FTX6271-Slipper Spring 1pc</p> 	<p>FTX6273 -Slipper Drive Cup 1pc</p> 	<p>FTX6262 -Bearing Bracket 1pc</p> 	<p>FTX6500 -Shock Ball End 6pcs</p> 
<p>FTX6501 -Servo Link Ball End 6pcs</p> 	<p>FTX6502 -Steering Linkage Ball End 6pcs</p> 	<p>FTX6507 -Ball B 6pcs</p> 	<p>FTX6506 -Ball A 6pcs</p> 
<p>FTX6508 -Ball C 6pcs</p> 	<p>FTX6510 -Shock 0-ring(Lower) 6pcs</p> 	<p>FTX6511 -Diff 0-ring Seal 6pcs</p> 	<p>FTX6580-Shock Seal Cover 4pcs</p> 
<p>FTX6513-Pin ϕ2*10 6pcs</p> 	<p>FTBB10 -Ball Bearing 15*10*4 6pcs</p> 	<p>FTX6515 -Ball Bearing 10*5*4 6pcs</p> 	<p>FTX6515 -E clip ϕ8mm 6pcs</p> 
<p>FTX6517-E clip ϕ2.5mm 6pcs</p> 	<p>FTX6516 -E clip ϕ4mm 6pcs</p> 	<p>FTX6581 -Front Lower Susp.Arm 2pcs</p> 	<p>FTX6582 -Rear Lower Susp.Arm 2pcs</p> 
<p>FTX6583 -Front CVD 2sets</p> 	<p>FTX6584-Upper Susp.Arm 4pcs</p> 	<p>FTX6585-Steering Arm 2pcs</p> 	<p>FTX6586 -Servo Linkage 1pc</p> 

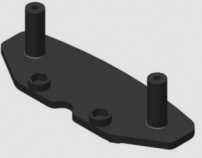

Part List

<p>FTX6523 -Round Head Self Tapping Hex Screw 3*10 8pcs</p> 	<p>FTX6522 -Round Head Self Tapping Hex Screw M3*6 6pcs</p> 	<p>FTX6525 -Button Head Hex Screw M3*8 6pcs</p> 	<p>FTX6526 -Button Head Hex Screw M3*10 6pcs</p> 
<p>FTX6527 -Button Head Hex Screw M3*12 6pcs</p> 	<p>FTX6528 -Button Head Hex Screw M3*14 6pcs</p> 	<p>FTX6535 -Flat Head Hex M3*8 6pcs</p> 	<p>FTX6536 -Flat Head Hex Screw M3*10 8pcs</p> 
<p>FTX6537 -Flat Head Hex Screw M3*12 6pcs</p> 	<p>FTX6538 -Flat Head Hex Screw M3*14 6pcs</p> 	<p>FTX6539 -Flat Head Hex Screw M3*18 3pcs</p> 	<p>FTX6540 -Flat Head Hex Screw M3*20 6pcs</p> 
<p>FTX6541 -Flat Head Hex Screw M3*36 6pcs</p> 	<p>FAST118 -Cap Head Hex Screw M3 X 18 6PCS</p> 	<p>FAST115 -Cap Head Hex Screw M3*10 6pcs</p> 	<p>FTX6530 -Ring Self Tapping Screw 3*4 4pcs</p> 
<p>FTX6543 -Set Screw M4*10 6pcs</p> 	<p>FAST123 -Set Screw M4*4 6pcs</p> 	<p>FAST122 -Set Screw M3*3 6pcs</p> 	<p>FASTM3 -Nylon Lock Nut M3 6pcs</p> 
<p>FTX6543 -Nylon Lock Nut M4 6pcs</p> 	<p>FTX6587 -Bumper sponge 1pcs</p> 	<p>FTX6588 -Sponge cover 1pcs</p> 	<p>FTX6589 -Bumper Rail 1pcs</p> 













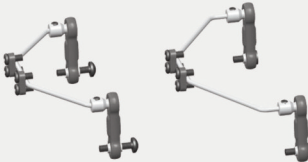
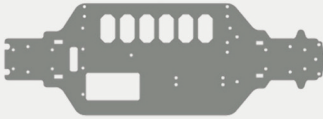

Part List

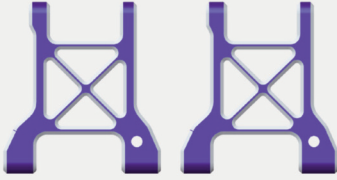
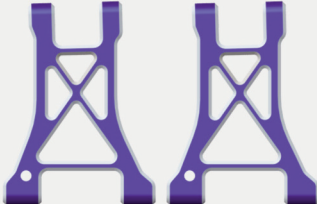
<p>FTX6590-Chassiss plate 1pcs</p> 	<p>FTX6591-Upper plate 1pcs</p> 	<p>FTX6592 -Bull board strengthen column 1pcs</p> 	<p>FTX6593 -Rear Dogbone 2pcs</p> 
<p>FTX6594 -Center Drive Shaft 1pcs</p> 	<p>FTX6595 -Hinge Pins(long & short) 1set</p> 	<p>FTX6599W-3kg/cm Servo 1pcs</p> 	<p>FAST0092B – Street/Drift Wheel & Tyre Set (4)</p> 
<p>ET1065 – Etronix 2.4ghz Sport ESR-1 Transmitter ET1090 – Etronix 2.4ghz Sport ESR-1 Receiver</p> 	<p>ET0411 Etronix 2.1W Brushless ESC</p> 	<p>FTX6551 -Body Clip(Small Size) 6pcs</p> 	<p>FTX6550 -Body Clip(Medium Size) 6pcs</p> 
<p>FTX6554 - 540 Brushed Motor 1pcs</p> 	<p>FTX6557W – 20A Waterproof Brushed ESC</p> 	<p>FTX6596 – Banzai Pre-printed body, decal & wing (un-cut)</p> 	<p>ET0330-335-3650(2950kv) Brushless Motor 1pcs</p> 
<p>VZ0010 – Voltz 1800mah NiMH Battery</p> 	<p>VZ0304 – Voltz 2500mah 7.4v 30C LiPo Battery (brushless esc only)</p> 		

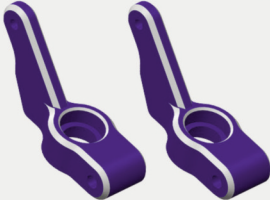

Upgrade Parts List

<p>FTX6487 -Sway Bar 1set</p> 	<p>FTX6488 -Chassis (Carbon) 1pc</p> 	<p>FTX6489 -Front Shock Tower (Carbon) 1pc</p> 	<p>FTX6490 -Rear Shock Tower (Carbon) 1pc</p> 
<p>FTX6491 -Upper plate (Carbon) 1pc</p> 	<p>FTX6492 -Front Lower Susp. Arm (AL) 2pcs</p> 	<p>FTX6493 -Rear Lower Susp. Arm (AL) 2pcs</p> 	<p>FTX6494 -Steering Knuckle Arm (AL) 1set</p> 
<p>FTX6495 -Rear Hub Carrier (AL) 2pcs</p> 	<p>FTX6496 -Battery cover (AL) 3pcs</p> 	<p>FTX6497 -Front bumper cover (Carbon) 1pc</p> 	<p>FTX6498 -Front Shocks (AL) 2pcs</p> 
<p>FTX6499 -Rear Shocks (AL) 2pcs</p> 			



Notes:

Notes section with horizontal dotted lines for writing.



BANZAI



www.ftx-rc.com



FTX is an exclusive brand of CML Distribution, Saxon House, Saxon Business Park,
Hanbury Road, Bromsgrove, Worcestershire, B60 4AD England.
E-mail: info@ftx-rc.com